

MOTOMAN GP8 FGG HS

Food Handling
in hygienic Environments



The MOTOMAN GP8 FGG HS (Food Grade Grease Hygienic Surface) is a very fast and precise 6-axis industrial robot with a payload of up to 8 kg especially for the food industry. With a reach of 727 mm and a high repeatability of ± 0.01 mm, it is ideally suited for universal handling or packaging tasks. Its modern, smooth, slim and award-winning industrial design minimizes the space required at the installation site.

The MOTOMAN GP8 FGG HS is designed with the high IP67 protection class as standard, is equipped with food-grade grease for tasks in the food industry and has an easy-to-wash surface with special anti-corrosive coating for use under aggressive environmental conditions.

The cable entry, optionally on the side of the base or from below through the base plate, enables space-saving and tidy integration into any machine, regardless of the intended installation position. The prepared media guide in the arm enables optimum integration of the gripper or sensor technology and an external media package can often be avoided.

With numerous functions of the MOTOMAN YRC1000 controller or the MOTOMAN YRC1000micro compact controller, a world of possibilities opens to the MOTOMAN GP8 FGG HS. In conjunction with the conventional teach pendant, this robot is a reliable partner for the food industry. With the innovative operating concept of the SmartPendant, it is an easy start to a fascinating world of robotics.

KEY BENEFITS

- Hygienic surface
- Optimized for food handling
- Fast and flexible
- Large working area: 727 mm
- Low interference contours due to optimized design
- Easy commissioning and maintenance

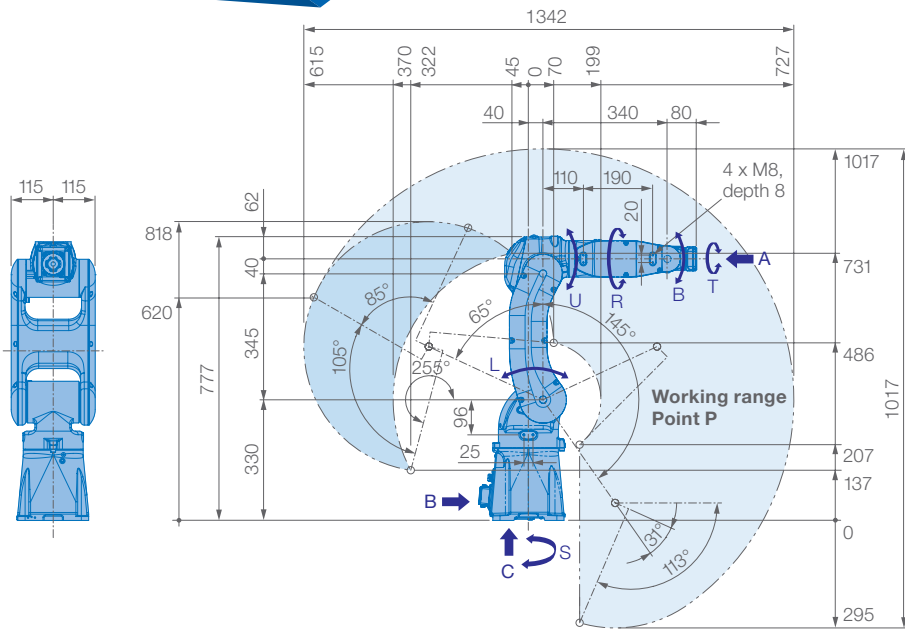

View A

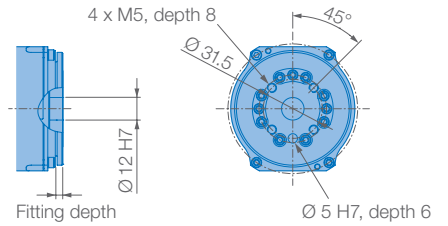

View B

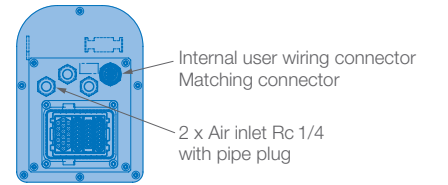

View C

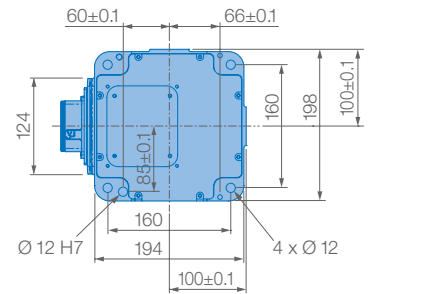

Mounting options: Floor, ceiling, wall, tilt*

IP Protection: IP67

Option: Cleanroom class 5

* tilt with condition of angle – see table below

Robot installation angle θ [deg.]	S-axis operating range [deg.]
$0 \leq \theta \leq 30$	± 170 degrees or less (no limit)
$30 < \theta \leq 35$	± 60 degrees or less
$35 < \theta \leq 45$	± 45 degrees or less
$45 < \theta$	± 30 degrees or less

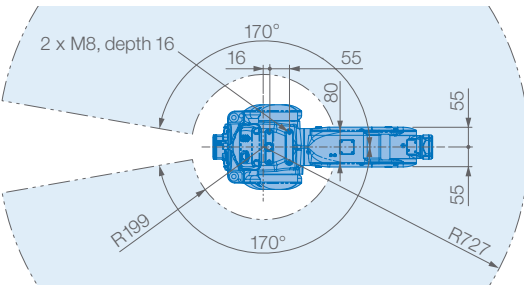

Prevent interaction of the robot with:

- Corrosive gases, liquids or explosive gases
- Exposure to water, oil or dust
- Excessive electrical noise (plasma)

Allowable wrist load

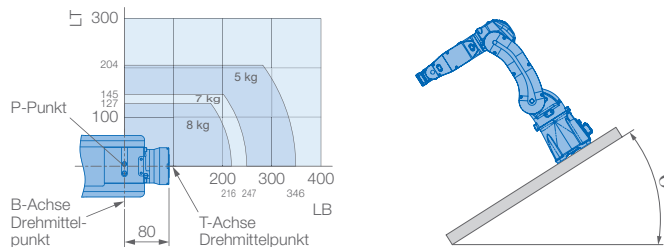

Specifications GP8 FGG HS						
Axes	Maximum motion range [°]	Maximum speed [°/s]	Allowable moment [Nm]	Allowable moment of inertia [kg · m ²]	Controlled axes	6
S	± 170	455	–	–	Max. payload [kg]	8
L	+145/–65	385	–	–	Repeatability [mm]	$\pm 0.01^*$
U	+190/–70	520	–	–	Max. working range R [mm]	727
R	± 190	550	17	0.5	Temperature [°C]	0 to +45
B	± 135	550	17	0.5	Humidity [%]	20 – 80
T	± 360	1000	10	0.2	Weight [kg]	35
					Power supply, average [kVA]	1**

* Conforms to ISO 9283 ** Varies in accordance with applications and motion patterns **Note:** SI units are used for specifications.

Yaskawa Europe GmbH

Robotics Division
Yaskawastraße 1
85391 Allershausen
Germany

Tel. +49 (0) 8166 90-0
robotics@yaskawa.eu
www.yaskawa.eu

YR-1-06VX8-F41
A-11-2022, A-No. 221001